



ATIMPEX Ltd. Ground Floor, 17 Bowater Road, LONDON SE18 5TF, WEE/BA2109UW
Tel.: 0207 450 5292 E-mail: support@ledcentre.uk.com

Installation manual for RGB LED strips with RF controller

Thank you for shopping at LEDcentre.uk.com.

We would like to help your electrician with the installation.



Specification of RGB strips:

Performance: 7.0 W/metre.

Operating Voltage: 12V DC, constant voltage

Voltage tolerance: 10-15V DC.

Operating the lights with batteries (ship, boat, yacht, caravan, van) voltage may go up while the battery is being charged. Strip lights are not affected by higher voltage within the tolerance rate for up to five hours.

Maximum length: 5 metre, separate, parallel power connection required for each 5 metre strip.

The strip light can be operated for up to 12 hours a day to keep its lifespan. It is not suitable for constant use.

Indoor: IP55 rating, splash proof, with silicone cover. The strip light has M3 adhesive tape on its back for easy installation.

Outdoor: IP68 rating, fully waterproof. No adhesive tape, for fixing we suggest using cable clips available in the shop or bathroom silicone.

Specification of RGB Controller:

Input and output Voltage: 12V DC, Operating temperature: -20 - +60°C, Recommended current: 4A to each colour, but maximum 6A. The RGB Controller can control up to a total 20 metres of the 30 SMD LED RGB strip. An RGB LED amplifier is necessary for every additional 20 meters of RGB LED strip powered by an additional 12V DC power supply (not included)

Power supply: We strongly recommend using our stabilised 12V DC power supplies. To calculate the required output of the LED driver, please use the power consumption details displayed on the product description. The total power consumption of 12V LED products connected to the power supply should never be higher than 90% of the output Wattage of the power supply.

Batteries: The advantage of the SMD LED products is that they operate at 12V DC, so 12V batteries are suitable for running them. If the charging of the battery is not regulated, it is advisable to include a voltage regulator within the system for the long lifespan of the lights.

The RGB LED strip light has cutting and connection points in every 100mm/4inch or after 3 LED units, so you can cut and join it to any size. The separate strips, they can be connected by wire, the splicing points are already on the strip for easier soldering.

Please note: Electronic transformers ruin the LED lights. If the light is damaged when used with unsuitable transformer, it loses its warranty.

Installation of the RGB controller:

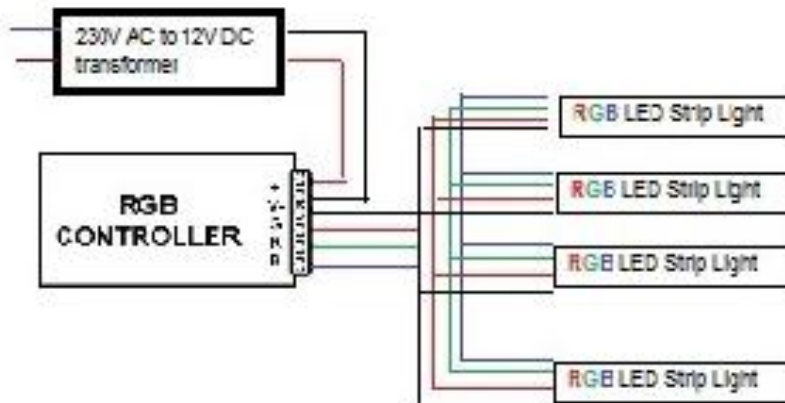

Only one power supply should be connected to RGB controller, primary or secondary.

Remote controller features:

Radio frequency system

Static Red, Green, Blue, White, Orange, Yellow, Cyan and purple colours.

AUTO: Moving all the modes automatically

JUMP 3: Three colours step change (speed and brightness are adjustable)

FADE 3: Three colours fade change (speed and brightness are NOT adjustable)

SPEED + : Increase speed

FLASH: Seven colours flash frequency (speed and brightness are adjustable)

JUMP 7 : Seven colours step change (speed and brightness are adjustable)

FADE 7 : Seven colours fade change (speed and brightness are NOT adjustable)

SPEED - : Decrease speed

The mains supply must always be isolated prior to installation. The overall electrical installation must conform to the relevant regulations.

Do not twist or step on the LED lights, as these can break the wires inside and the strip lights are flexible to one direction only.

The LEDcentre does not take any responsibilities for personal injuries or damage of the goods caused by incorrect installation. All installation must be carried out by qualified persons.