

## Installation manual for RGB amplifier



Thank you for shopping at LEDcentre.uk.com

We would like to help your electrician with the installation.

The RGB signal amplifier is used to increase load capability for the wireless RGB Controller. An RGB LED signal amplifier is necessary for every additional 20 metres of RGB LED strip lighting powered by additional 12V DC power supply (not included) if you need to operate long or multiple lengths of RGB LED strip and want to use just one remote controller to synchronise the effects. One controller will be needed in any case to create the effects and colours of the RGB LED strip and then the amplifier will work as a slave to this controller.

The amplifier is required to be connected to the controller, utilising the RGB and positive cables, these will carry the signal commands as an input to the amplifier. Connect input and output signal wires in order to ensure short circuit can not occur between wires, and then connect power to RGB amplifier, and RGB amplifier goes hand in hand with LED controller.

**Power supply:** We strongly recommend using our stabilised 12V DC power supplies. To calculate the required output of the LED driver, please use the power consumption details displayed on the product description. The total power consumption of 12V SMD LED products connected to the power supply should never be higher than 90% of the output Wattage of the power supply.

**Please note: Electronic transformers ruin the LED lights. If the light is damaged when used with unsuitable transformer, it loses its warranty.**

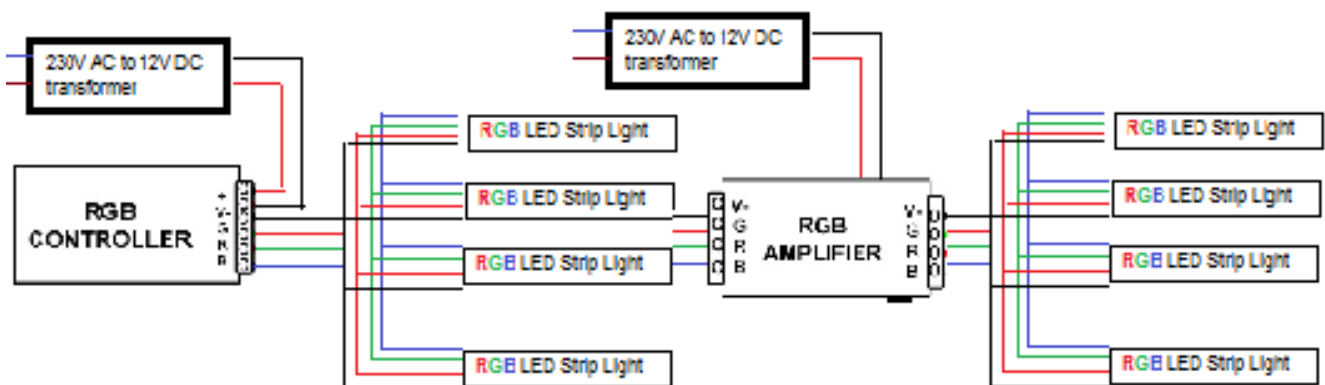

### Specification of amplifier:

Operating temperature: from -20C/4F to +60C/140F, input and output voltage: 12V DC, 144W max  
**Maximum length:** 5 metre, separate, parallel power connection required for each 5 metre strip.

**The mains supply must always be isolated prior to installation. The overall electrical installation must conform to the relevant regulations.**

The LEDcentre does not take any responsibilities for personal injuries or damage of the goods caused by incorrect installation. All installation must be carried out by qualified persons.